

Future Fuels.

**KRAL**



## When Future Meets Experience. KRAL screw pumps and flowmeters for Future Fuels.

In the ever-changing world of energy technologies, future fuels play a key role. They do not only promise a more sustainable alternative to conventional fossil fuels, but also drive innovation and efficiency in various industrial applications. The KRAL Future Fuels pump offers high efficiency for various Future Fuels and a wide range of applications thanks to the use of corrosion-resistant stainless steels.

## Approved Technology With Compact Design.

Compared to other pump models, KRAL screw pumps offer high flow rates with a small footprint. The pumps are self-priming, deliver with low pulsation and low noise levels and are characterized by low maintenance requirements and a long operating life.

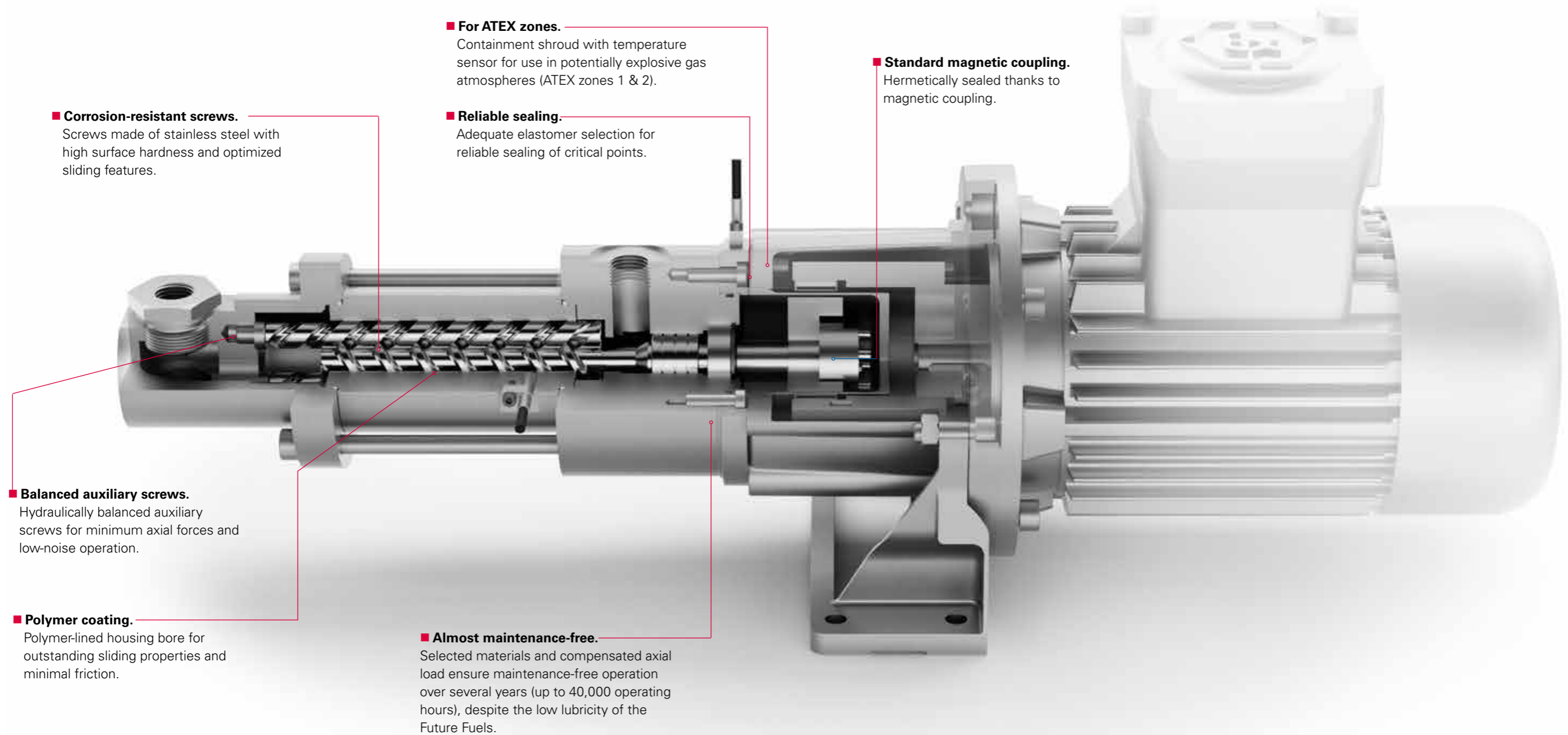

## F Series.

KRAL screw pumps for Future Fuels.

### At a glance.

- All media wetted parts made of stainless steel.
- Hermetic sealing with magnetic coupling.
- Approved for use in in ATEX Zone 1 & 2.
- Differential pressures up to 80 bar (LFO, biofuels) / max. 60 bar for methanol and up to 40 bar for ammonia.
- Excellent efficiency degree.
- Low pulsation and low shear conveying.
- Almost linear conveying characteristics.
- Very low noise emissions.
- Suitable for fuels with acid value > 0.5 mg KOH/g.

### Performance data tailored to Future Fuels.

- Delivery rate: 5 to 280 l/min.
- Viscosity: 0.2 to 500 mm<sup>2</sup>/s.
- Rotation speed: up to 4,000 min<sup>-1</sup>.
- Differential pressure: up to 120 bar.

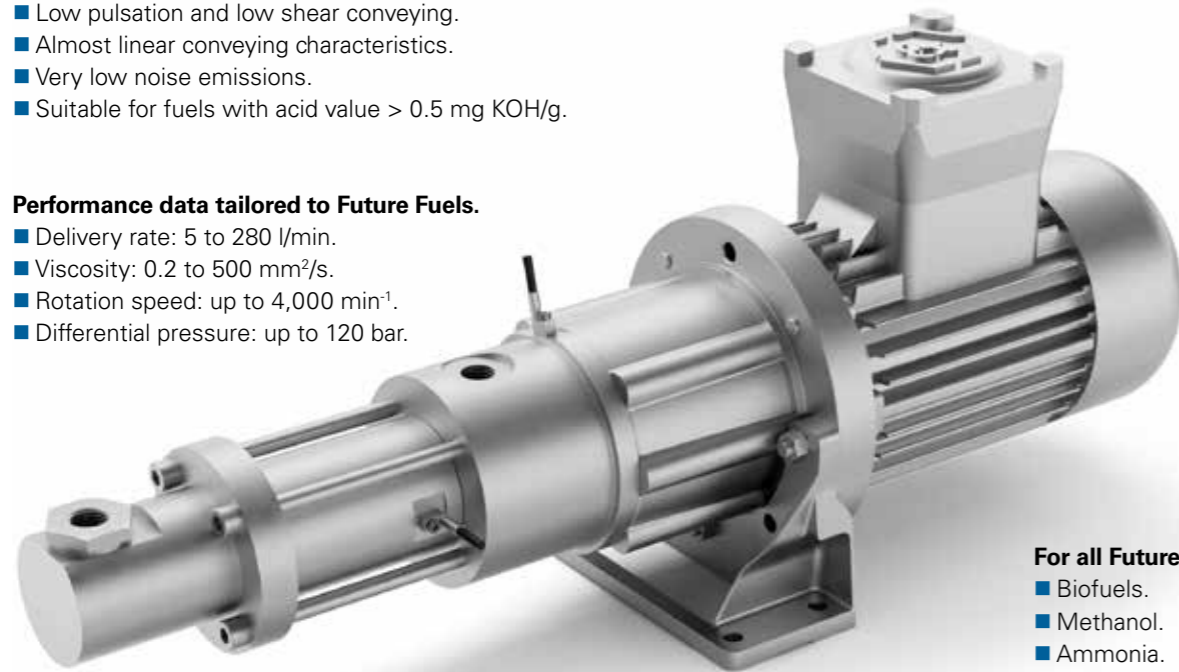

### For all Future Fuels.

- Biofuels.
- Methanol.
- Ammonia.
- Ethanol.
- LFO.
- HVO.
- FAME.

Technical Data.	Models.				
	15-20	32-42	55-74-85	105-118	
<b>Delivery rate</b> 2.900 min <sup>-1</sup> , 40 bar, 1 mm <sup>2</sup> /s	l/min	up to 25	up to 60	up to 120	up to 180
<b>Max. differential pressure</b>	bar	120	120	120	120
<b>Max. temperature</b>	°C	80	80	80	80
<b>Viscosity</b>	mm <sup>2</sup> /s	>0,2	>0,2	>0,2	>0,2
<b>Rotation speed</b>	min <sup>-1</sup>	4,000	4,000	4,000	4,000
<b>Max. supply pressure</b>	bar	16	16	16	16

## OMS Series.

Stainless steel flowmeters for demanding media.



**For low viscosity media.**  
Design with ball bearings.



### Your benefits.

- High precision.
- Extremely robust.
- Stabilization zones unnecessary.
- Low friction and minimal loss of pressure.
- Very compact design.

### Materials.

- Housing: Stainless steel.
- Screws: Stainless steel.
- Ball bearing: Stainless steel
- Seal: Viton®.

Technical Data.	Low viscosity media.			
	OMS-020	OMS-032	OMS-052	OMX*
<b>Nominal diameter</b> DN [Zoll]	¾	1	1½	½ to 6
<b>Flow rate l/min</b>	[Q <sub>max</sub> ]	45	150	525
	[Q <sub>nenn</sub> ]	<b>30</b>	<b>100</b>	<b>350</b>
	[Q <sub>min</sub> ]	0.6	2.0	7.0
<b>Max. pressure.</b>	[bar]	185	185	120
<b>Temperature</b>	[°C]	-20 to +150	-20 to +150	-20 to +150
<b>Viscosity</b>	[mm <sup>2</sup> /s]	>0.2	>0.2	>0.2
<b>Precision</b> of measurement value		±0.1 %	±0.1 %	±0.1 %
<b>K-factor</b>	[P/l]	1,280	468	142
<b>Frequency</b> at Q <sub>nenn</sub>	[Hz]	640	780	828
				8.8 to 7,296 depending on the model size
				203 to 3,758 depending on the model size

\*The maximum values for the OMX series can be implemented individually but cannot necessarily be combined. Exact values on request.



## Service From A Single Source.

Short reaction times. Fast and competent.

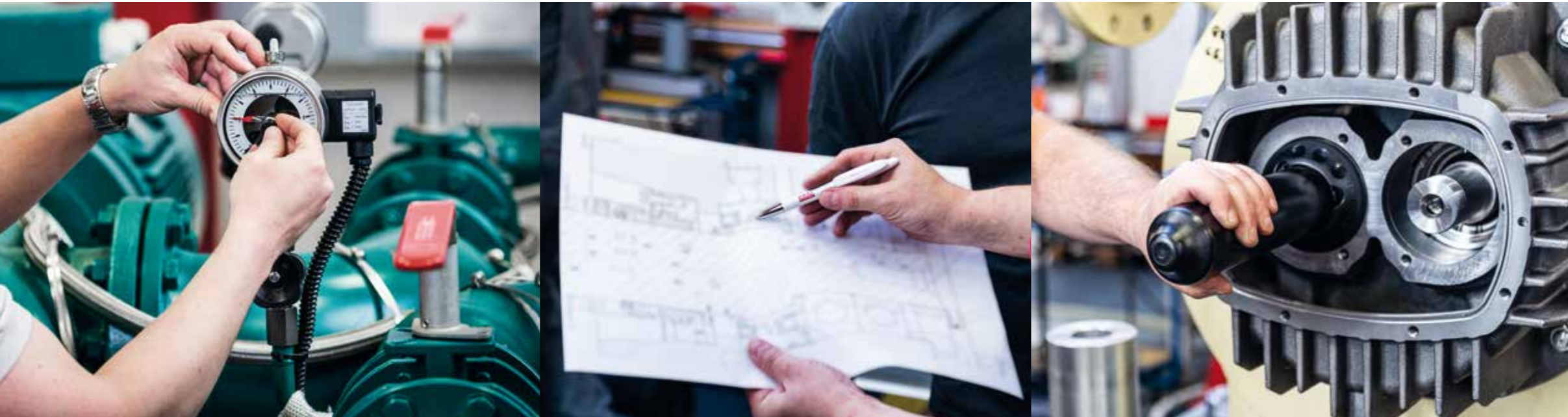

### Installation and commissioning.

We can help you install and commission your KRAL products upon request. Professional installation and optimal deployment of the pumps are prerequisites for error-free operation. Our technicians not only know our products; they also know how the system affects the pump and can configure the latter accordingly for optimal performance.

As a customer, you benefit from our wealth of experience, because we've commissioned large numbers of KRAL pumps at our customers' premises.

### Training.

KRAL training provides you with in-depth knowledge on installing, commissioning, and maintaining your KRAL product. You receive expert information from the manufacturer on how to install and commission your KRAL product properly, and you learn about various applications and utilization limits. You also learn to identify and rectify faults based on actual damage profiles.

We lead you through a professional maintenance routine and show how you can reduce your product's operating costs. The training can be held either at our headquarters in Lustenau or at your premises, upon request.

### Maintenance and repair.

Downtime can generate substantial costs. Increase the operational safety and minimize the life-cycle costs of your KRAL product through the preventative maintenance services provided by our competent service team. When a breakdown occurs, our service technicians react quickly and arrive at your premises in no time. When you make a repair shipment, confirmation of receipt is sent to you as soon as the shipment arrives. Each time a repair is made, we send you a comprehensive technical report together with detailed images.

We perform maintenance work and repairs at our headquarters in Lustenau, Austria or at your premises, upon request. And the genuine KRAL parts we use guarantee the highest standards of quality.

### Spare parts.

KRAL pumps meet the highest quality standards. To ensure those standards are maintained, you should only use genuine KRAL parts as spare parts. They guarantee that your pumps maintain a high level of quality, continue to operate smoothly, and last a long time.

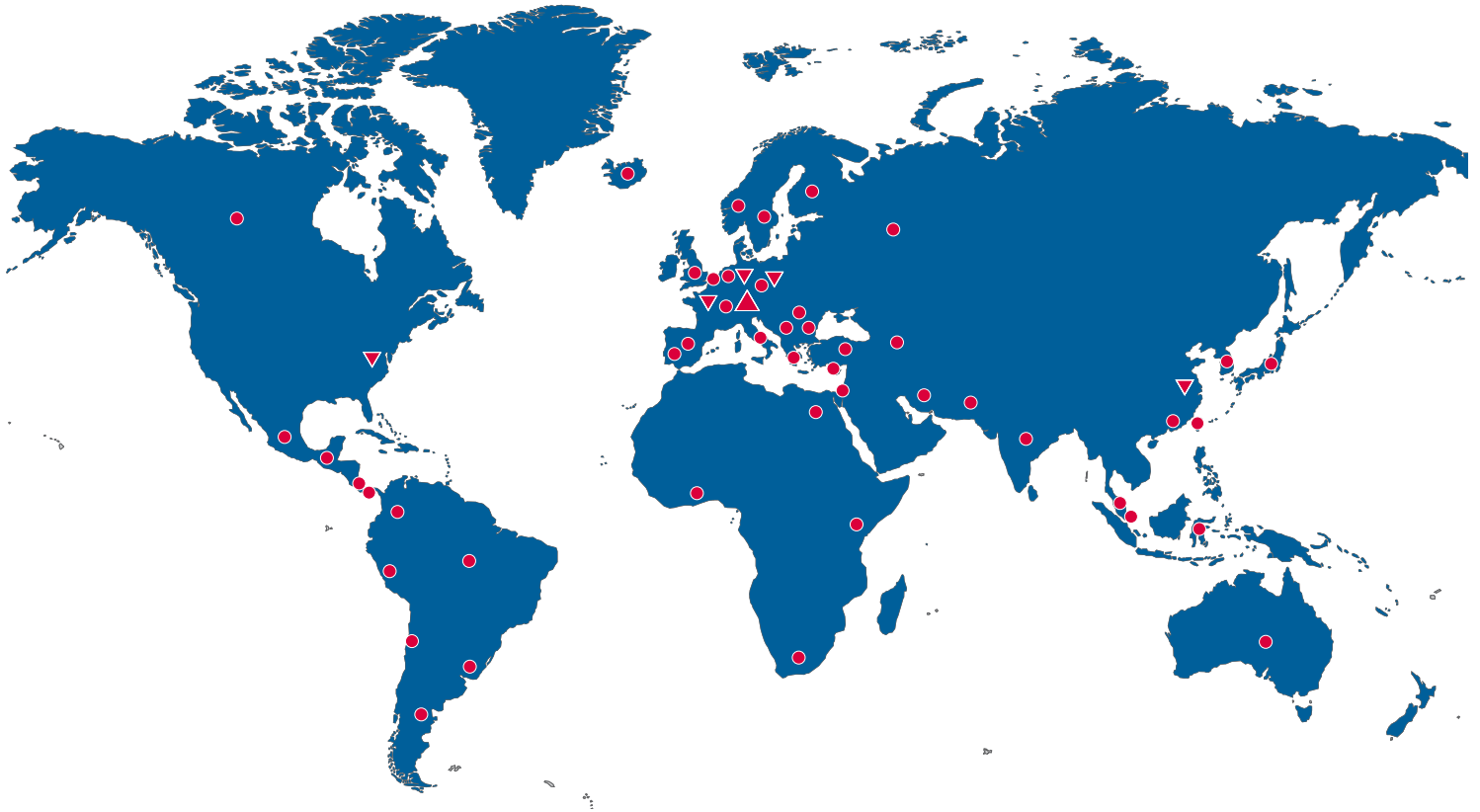

#### Headquarters.

##### **KRAL GmbH**

Bildgasse 40, Industrie Nord  
6890 Lustenau, Austria  
e-mail: [kral@kral.at](mailto:kral@kral.at)  
Tel.: +43/5577/86644-0

#### Further locations.

##### **KRAL Deutschland GmbH**

88131 Lindau  
Germany

##### **KRAL Polska Sp. z o.o.**

40-668 Katowice  
Poland

##### **KRAL SAS**

69100 Villeurbanne  
France

##### **KRAL-USA, Inc.**

28105 Matthews, NC  
USA

##### **KRAL (Wuxi) Machinery Technology Co., Ltd.**

214100 Wuxi  
China